

**Title:**

A contact resistance measurement setup for the study of novel contacts

**Authors:**

Rafael Puyol, Sebastián Suárez

© 2017 IEEE. Personal use of this material is permitted. Permission from IEEE must be obtained for all other uses, in any current or future media, including reprinting/republishing this material for advertising or promotional purposes, creating new collective works, for resale or redistribution to servers or lists, or reuse of any copyrighted component of this work in other works.

**Cite as:**

R. Puyol and S. Suárez, „A contact resistance measurement setup for the study of novel contacts“, *2017 IEEE URUCON*, Montevideo, 2017, pp. 1-4. DOI: [10.1109/URUCON.2017.8171881](https://doi.org/10.1109/URUCON.2017.8171881)

URL: <https://ieeexplore.ieee.org/document/8171881>



# A Contact Resistance Measurement Setup for the Study of Novel Contacts

Rafael Puyol

Electrical Engineering Department  
Universidad Católica del Uruguay  
Montevideo, Uruguay  
rpuyol@ucu.edu.uy

Sebastián Suárez

Department of Material Science and Engineering  
Saarland University  
Saarbrücken, Germany  
s.suarez@mx.uni-saarland.de

**Abstract**—Contacts are a key component of most modern electrical and electronic systems, they are found in connectors, switches and relays. Recently it has been proposed the usage of new composite materials in contacts; this demands the study and characterization of these materials to assess their performance. From the electrical perspective, the most important aspect is the resistance and its variations due to mechanical and chemical phenomena. The measurement of contact resistance carries some challenges due to the low values to be measured and the limitations imposed by dry circuit testing. In this article, we present a setup suitable for making low resistance measurements as those found on electrical contacts.

**Keywords**—resistance measurement; electrical connectors

## I. INTRODUCTION

Electrical connectors are widely used in automotive, consumer electronics, aerospace and medical applications, amongst several other engineering fields. Their main function is to close an electrical circuit, reliably transporting current throughout the contact surface. It has been extensively reported that, specifically in the automotive industry, the degradation of the connectors has been one of the main causes of erratic behaviour in the electrical circuit. As a clear example of this problematic, it has been estimated that 60% of electrical problems in modern automobiles are caused by faulty connectors [1]. This trend is likely to continue with the advent of electric cars.

In service, these stationary components are subjected to electrical, chemical and mechanical aspects. The three effects are strictly intertwined. For example, a connector in the signal or control (low DC voltage and current [2]) circuit of a car is usually exposed to a chemically aggressive environment (increased local temperature in uncontrolled atmosphere), leading to a corrosion/oxidation of the contacting surfaces. This derives in a locally increased contact resistance (localized Joule heating) and surface brittleness (prone to fretting wear degradation). The combination thereof thus results in a decreased duty life of the component.

The design of the electrical connectors must then be performed considering the aforementioned features. As described by Holm [3], two mating real surfaces (with their respective roughness) present inevitably a certain contact (constriction) resistance due to the intimate junction of

asperities. This resistance is dependent upon the real contact area and therefore, on the applied mechanical load between the surfaces. Hence, the selection of the material is restricted mainly to ductile metals, which could reduce the contact resistance by increasing their plastic deformation. Currently, the most widespread material system used in low voltage DC connectors is a multilayer arrangement of Tin (Sn) onto a Copper (Cu) core. The superficial tin layer is soft enough to absorb the mechanical deformation, increasing the effective contact area. However, tin is readily oxidized leading to a quicker surface degradation, as opposed to the more suitable (but economically unfavourable) noble metals (i.e. Ag, Au, etc.).

Researchers have proposed the integration of carbon nanotubes (CNT) as reinforcements in metal matrix composites to improve the electrical and mechanical properties of low-voltage relay electrodes [4]. CNTs have shown the theoretical capability of conducting electrons ballistically, reducing the Joule heat losses to negligible values.

Due to the lack of a standardized procedure to assess the performance of these materials, it is of utmost importance to develop a reliable and repeatable measurement process. For that, the service conditions of the connector must be considered from the electrical and mechanical point of view (with regard to the parameters' values sweep).

This work presents a measurement setup capable of determining contact resistances in the  $\mu\Omega$  range. The first section explains the measurement process and dry circuit testing. The second presents the measurement setup and an analysis of its capabilities, the last section exemplarily shows two experimental results obtained from a Sn/Cu commercial multilayer system.

## II. MEASUREMENT PROCESS AND DRY CIRCUIT TESTING

Contacts are electrical components generally used in pairs to allow current flow in a circuit when touching or to interrupt it when breaking apart. Even though they should ideally exhibit zero resistance, real contacts have resistance that generates heating and voltage drops. The four-terminal sensing technique was chosen for this setup, to minimize external influences such as cables resistances.

Electrical contacts are complex metallic systems which can be easily altered by the test currents, voltages and forces

applied during testing. This has led to the development of what is known as the dry circuit testing (DCT). DCT conditions require that the contact behavior is determined by the chemical and mechanical characteristics. The available voltage must be low enough so as to avoid creating an electric discharge when the circuit is open [5]. Also oxidation puncture must be avoided, otherwise the oxide layer will be broken and the measured resistance will be lower [6]. The idea is to keep the electrical performance of the contact intact [5]. The actual voltages a contact can tolerate without damage depends on its chemical composition, typical values are below 100mV [5]. For this experiment two contacts are used, one which is the device under test (DUT) and the other which is a gold terminal as explained in the following section.

### III. MEASUREMENT SETUP

#### A. Description

To measure the contact resistance, the four-terminal DC feed technique is used. A schematic of the system is presented in figure 1 including the equipment interconnections. The current is generated by a Keithley 2400 SMU and the voltage drop is measured with a Keithley 2182A nanovoltmeter.

The contact resistance is dependent on the applied force which is controlled by the mechanism shown in figure 2. The DUT is placed on a highly precise linear stage and the other contact which is a golden tip is fixed through a force sensor to the rig. To control the force, the linear stage is placed in a feedback loop with the force sensor and a proportional controller implemented in Labview. The linear stage platform is made of plastic which acts also as insulator as the rest of the hardware is metallic. The Labview application also controls the SMU and the nanovoltmeter.

A Me-Systeme KD-24±10N force sensor and a PI M-683.2U4 linear stage with a resolution of 0.1µm are used.

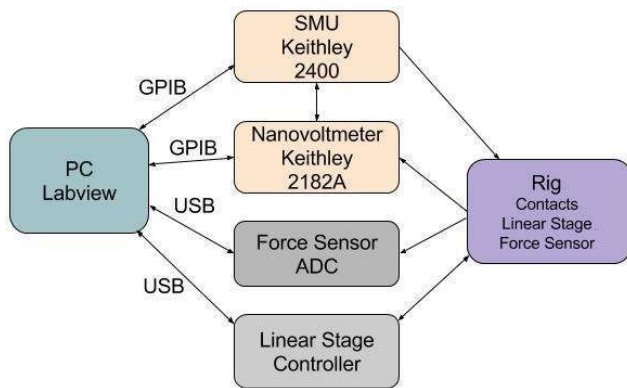

Fig. 1. Schematic of the setup.

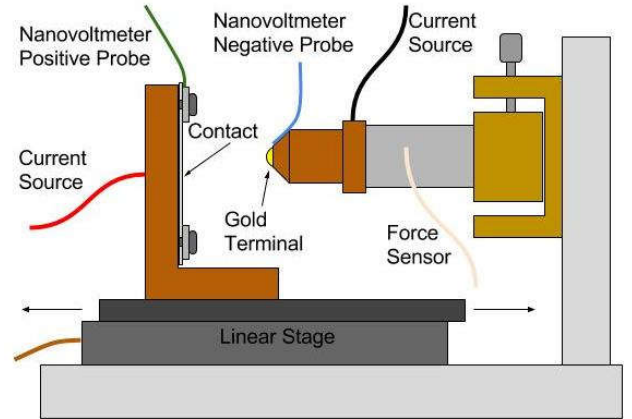

Fig. 2. Schematic of the test rig with a linear stage and a force sensor to apply and control the contact force.

The force sensor accuracy is %0.1. After some trials, it was observed that forces in the range of 0.25N to 10N are achievable with a relative error below 10%. The error decreases for larger forces, above 1N the error was typically around 1%.

The setup is placed in a room at constant temperature. Although the cables and connectors are made of different materials no temperature gradients that could lead to thermoelectric effects were observed in the circuit, still the nanovoltmeter includes the current reversal modes.

#### B. Accuracy

Initially no time constraints are imposed so the instruments can be configured for best accuracy. Table 1 presents the accuracy of the SMU and the nanovoltmeter for different ranges and a 1 year calibration period [7], [8]. Equation 1 is used to compute the uncertainty of the resistance measurement.

TABLE I. EQUIPMENT CONFIGURATIONS

Instrument	Range	Accuracy ± (reading + range)
Keithly 2400 as current source	100 mA	±(0.066% + 20µA)
Keithly 2182A	100 mV	±(30ppm + 4ppm)
Keithly 2182A	10 mV	±(50ppm + 4ppm)

$$\left| \frac{\Delta R}{R} \right| = \sqrt{\left( \frac{\Delta I}{I} \right)^2 + \left( \frac{\Delta V}{V} \right)^2} \quad (1)$$

Figure 3 presents the measurement uncertainty as a function of the contact resistance for two nanovoltmeter range configurations, 10mV and 100mV. Resistances larger than 50µΩ can be measured with an uncertainty below 1%. To increase the accuracy even further the nanovoltmeter should be replaced with a more accurate instrument, like an electrovoltmeter.

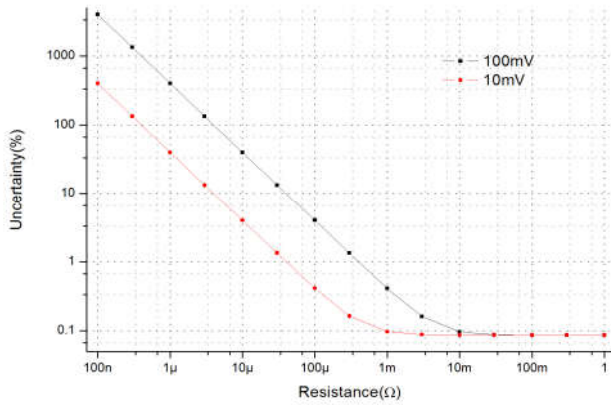

Fig. 3. Uncertainty in the resistance measurement as a function of the resistance.

#### IV. MEASUREMENTS

Tests on two commercially available contact materials were carried out. Both samples are strips of Tin coated Copper. The samples were cleaned with DeoxIt® D-Series cleaning solution just before the experiment, so as to remove organic remains from the sample handling. The test current was set to 100mA and the range of the nanovoltmeter to 100mV.

The aim of both experiments is to measure the contact resistance for a sequence of applied forces. First, the forces are applied in increasing order and once the largest load is measured, the same sequence is applied backwards. This cycle is repeated several times. For each force, several measurements are acquired, to be later averaged. Figure 4 presents 15 cycles of measurements (only odd cycles are shown) with forces in the range of 1.5N to 10N. For each force 10 samples were taken and averaged; error bars indicate the standard deviation. Figure 5 shows a similar experiment in which fewer cycles were performed but a greater amount of forces was applied, this time in the range of 0.25N to 10N. Figure 6 shows the applied and measured forces as well as the relative error for the first cycle of the second experiment. As expected the error is larger for smaller forces.

The smallest measured resistance is in the range of hundreds of  $\mu\Omega$ , so as explained in the previous section, the equipment is adequate for the experiment. On the other hand, the largest resistance which is smaller than  $5m\Omega$  generates a voltage drop below 1mV, so the nanovoltmeter can be configured for best accuracy.

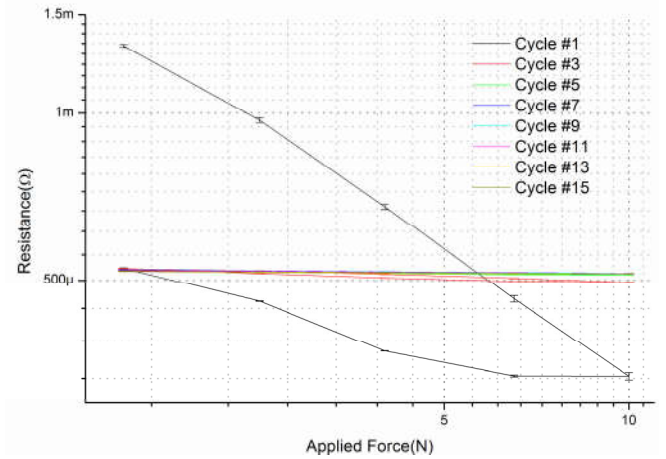

Fig. 4. Resistance as function of the Applied Force for 15 cycles (only odds are show).

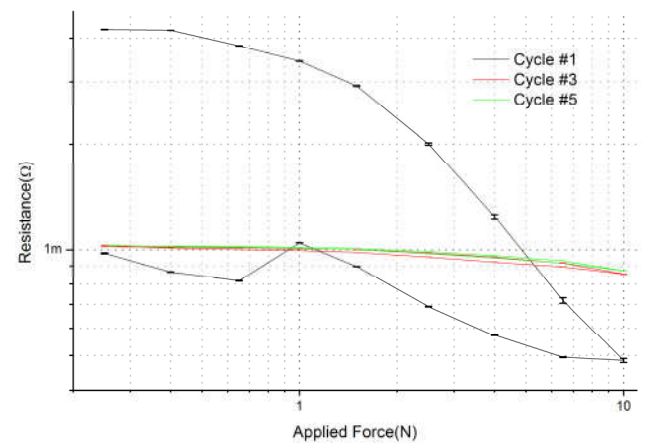

Fig. 5. Resistance as function of Applied Force for 5 cycles (only odds are shown).

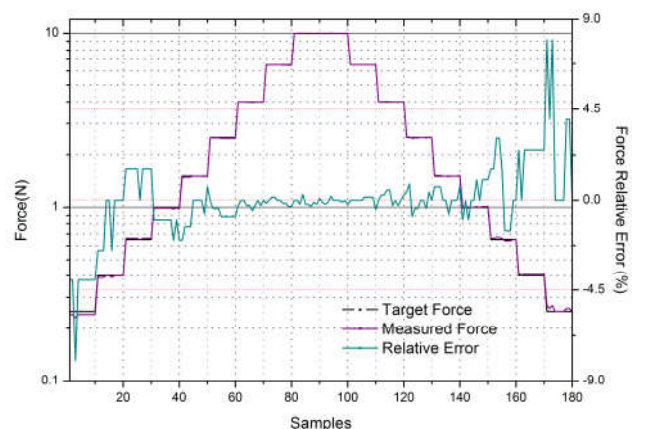

Fig. 6. Evolution of Target Force, Measured Force and Relative Error with time.

## V. CONCLUSIONS

A measurement setup designed for the study of electrical contact resistance is presented. Its accuracy is adequate for the typical values found in materials used in classical contacts and can be configured for dry-circuit testing. Although an improvement in conductance is expected from new materials, the setup is still accurate for resistances as low as  $50\mu\Omega$ .

Two experiments on metallic contacts were carried out to validate the measurement procedure as well as the force control and its error, both validated the design goals.

## VI. ACKNOWLEDGMENT

S. Suarez wishes to acknowledge the EFRE Funds of the European Commission for support of activities within the AME-Lab project. This work was supported by the CREATE-Network Project, Horizon 2020 Program of the European Commission (RISE Project Nr. 644013).

## VII. REFERENCES

- [1] T. Gissilia, "Connectos and Vibrations-Damages in Different Electrical Environments" M.S. Thesis, Department Of Mechanical Engineering, Blekinge Institute of Technology, Karlskrona, Sweden, 2013.
- [2] P. G. Slade, *Electrical Contacts: Principles and Applications*, 2nd ed. Boca Raton, FL: CRC Press, 2014.
- [3] R. Holm, *Electric Contacts Theory and Application*, 4th ed. Berlin, Germany, Springer-Verlag GmbH, 1967.
- [4] S. Suarez, N. Souza, F. Lassarre, F. Mücklich, "Influence of the Reinforced Distribution and Interface on the Electronic Transport Properties of MWCNT-Reinforced Metal Matrix Composites", *Advanced Engineering Materials*, DOI: 10.1002/adem.201600216.
- [5] L. Jedynak and C. H. Kopper, "Instrumentation for Measuring Dry-Circuit Contact Resistance", *IEEE Transactions on Parts, Hybrids, and Packaging*, Vol. Php-11, No.2, June 1975.
- [6] *Low Level Measurement Handbook*, 7<sup>th</sup> ed., Tektronix Inc., Beaverton, OR, pp. 3-27-3-28.
- [7] Tektronix, "SourceMeter SMU Instruments", 2400 datasheet, Dec. 2016.
- [8] Keithley, "Nanovoltmeter", 2182A datasheet, .
- [9] K. Trinh, E. Ramos-Moore, I. Green, C. Pauly, M. Zamanzade, and F. Mücklich - Topographical and microstructural effects of laser surface texturing on Tin-coated copper electrical connectors under load cycling. *IEEE Trans. on Components, Packaging and Manufacturing*, Vol. 7 Issue 4 (2017), pp. 582-590. DOI: 10.1109/TCPMT.2017.2659224